

# CSACSW/CSACLSW

## ソリッド

## Wアングュラーカッター

Solid Carbide Angular Cutter With Straight Shank

### CSACSW

### CSACLSW

突き出しの長い加工に対応したロングサイズ  
long size for long protrusion processing.

### 切削条件参考表 Cutting Condition Table

直径 Dia.	非鉄金属 Al,Cu		炭素鋼 FC,FCD,S50C		合金鋼 SCM,SKD,SUS304		調質鋼 HPM,NAK	
	切削速度 Cutting speed 15~30m/mm		切削速度 Cutting speed 12~20m/mm		切削速度 Cutting speed 10~16m/mm		切削速度 Cutting speed 8~14m/mm	
	回転数 spindle speed rpm	送り feed mm/min	回転数 spindle speed rpm	送り feed mm/min	回転数 spindle speed rpm	送り feed mm/min	回転数 spindle speed rpm	送り feed mm/min
15xW 90°	318 ~ 637	32 ~ 101	255 ~ 424	17 ~ 58	212 ~ 340	14 ~ 46	170 ~ 297	10 ~ 20
20xW 90°	239 ~ 477	29 ~ 90	191 ~ 318	15 ~ 51	159 ~ 255	13 ~ 41	127 ~ 223	9 ~ 18
25xW 90°	191 ~ 382	27 ~ 83	153 ~ 255	14 ~ 47	127 ~ 204	12 ~ 38	102 ~ 178	8 ~ 17
30xW 90°	159 ~ 318	25 ~ 79	127 ~ 212	13 ~ 45	106 ~ 170	11 ~ 36	85 ~ 149	7 ~ 16
15xW120°	318 ~ 637	37 ~ 116	255 ~ 424	20 ~ 66	212 ~ 340	17 ~ 53	170 ~ 297	11 ~ 23
20xW120°	239 ~ 477	33 ~ 103	191 ~ 318	18 ~ 59	159 ~ 255	15 ~ 47	127 ~ 223	10 ~ 21
25xW120°	191 ~ 382	31 ~ 95	153 ~ 255	16 ~ 54	127 ~ 204	14 ~ 43	102 ~ 178	9 ~ 19
30xW120°	159 ~ 318	29 ~ 90	127 ~ 212	15 ~ 51	106 ~ 170	13 ~ 41	85 ~ 149	9 ~ 18

**EIKO** 株式会社 栄工舎  
EIKOSHA CO., LTD.  
<https://www.eiko-sha.co.jp/>



EIKO TOOL



# CSACSW/ ソリッドWアンギュラーカッター CSACLSW Solid Carbide Angyular Cutter With Straight Shank

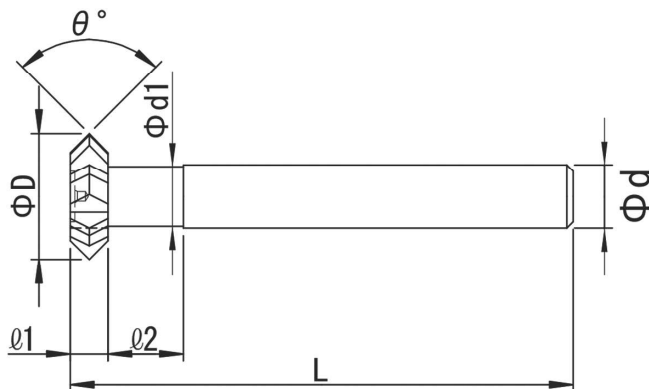

右直刃

超微粒子

右刃ストレート 超微粒子  
Straight Flute Ultra Micro Grain Carbide

公差 (Tolerance)    D:  $^{+0.1}_0$      $\theta : \pm 15'$     d: h6

## CSACSW

刃径 (φD) Dia.	角度 (θ) Cut Angle	刃厚 (ℓ1) Cut Width	首径 (φd1) Neck Dia.	首長 (ℓ2) Neck Length	全長 (L) Overall Length	シャン径 (φd) Shank Dia.	刃数 (N) Number of Flutes
15	W 90°	5	5.5	15	80	6	6
20		6	9.5	12	80	10	6
25		7	11.5	12	80	12	6
30		8	11.5	12	80	12	6
15	W120°	6	5.5	15	80	6	6
20		8	9.5	12	80	10	6
25		8	11.5	12	80	12	6
30		10	11.5	12	80	12	6

## CSACLSW

刃径 (φD) Dia.	角度 (θ) Cut Angle	刃厚 (ℓ1) Cut Width	首径 (φd1) Neck Dia.	首長 (ℓ2) Neck Length	全長 (L) Overall Length	シャン径 (φd) Shank Dia.	刃数 (N) Number of Flutes
15	W 90°	5	5.5	15	130	6	6
20		6	9.5	12	130	10	6
25		7	11.5	12	130	12	6
30		8	11.5	12	130	12	6
15	W120°	6	5.5	15	130	6	6
20		8	9.5	12	130	10	6
25		8	11.5	12	130	12	6
30		10	11.5	12	130	12	6

株式会社 栄工舎  
EIKOSHA CO., LTD.

本社・東京営業所 Head Office/Tokyo Sales Office

〒144-0052 東京都大田区蒲田 3-16-12  
3-16-12 Kamata Ota Ward 144-0052 Tokyo  
TEL 03-3738-3970 FAX 03-3732-3665

大阪営業所 Osaka Sales Office

〒532-0011 大阪市淀川区西中島 7-6-12  
新大阪駅前和光ビル 801号  
7-6-12 Nishinakajima Yodogawa Ward  
532-0011 Osaka  
TEL 06-6838-3936 FAX 06-6838-3937



ISO 9001:2015